



Application area

- To depart from coffee beans or peeling of oats, sunflower and other grains and oilseeds after spin - impact - Principle

Principle of operation

- The product is running in three separate product streams and fed to the three levels of the blower wheel
- The product is dropped on the rotating spinner and this is deflected in radial direction, speed, focus and spun at high speed with the tip against the impact ring
- Of the impact ring is the product led to the exit

Main features

- Spinner consisting of 3 levels
- Impact rings coated with anti-wear „Rhino-Hyde“
- Rapid change of impact rings
- Large inspection openings and openings for maintenance
- Welded stainless steel sheet housing
- Optional connection Aspirations
- ATEX conformity available on request

Centrifugal Husker FS 410/3

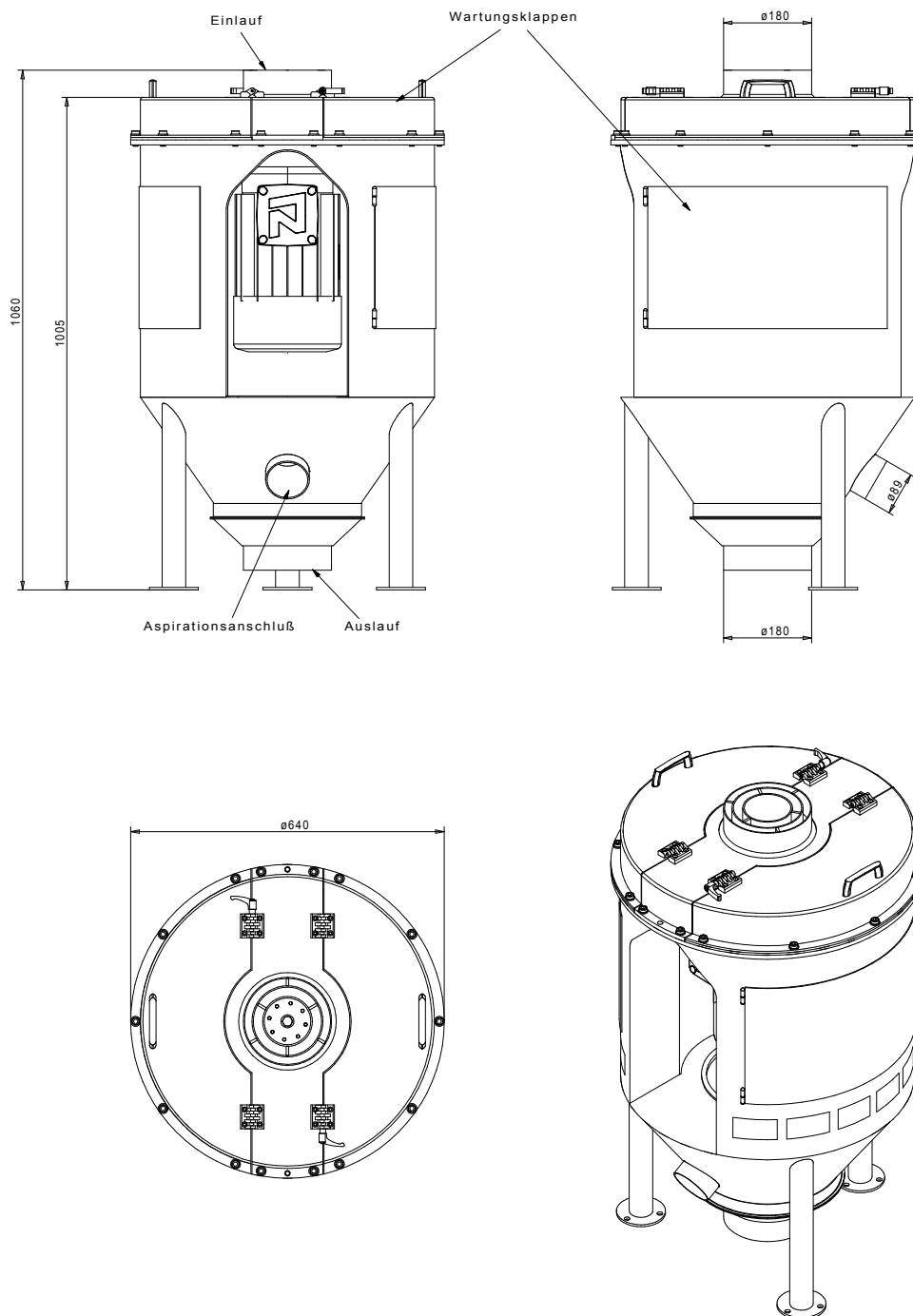

Type	Capacity*	Driving power	Speed of nose fairing	Air flow for aspiration	Weight
	(kg/h)	(kW)	(U/min)	(m ³ /min)	(kg)
FS 410 / 3	ca. 1000 - 4800	5,5	750 - 3000	10	130

* Dependent on species and product attributes.

We reserve the right to make technical modifications.
MMW 2012/03