

CESCO Roller Belt Conveyors are designed with a flexible and modular concept, allowing for gentle horizontal or slightly inclined conveying of cereals, meals, pellets, and various granular products. These conveyors ensure completely sealed product conveyance, with zero loss during transport, easy cleaning, maintenance, and operational safety thanks to the comprehensive bolted system utilized.

The fully enclosed version RBCE is designed specifically for situations demanding a dust-free environment. This conveyor system fully encases its components, effectively eliminating dust emissions and safeguarding grains from external contaminants. Ideal for grain collection facilities, grain terminals, ship loading/unloading, and various grain processing applications, the RBCE transport transoms are fitted with three independent cylindrical idlers for high reliability and easy maintenance, which can be exchanged from outside the conveyor. With a wide range of available belt sizes, it can transport up to 1000 tons per hour, making it the efficient and clean solution for your material handling needs.

GENERAL CHARACTERISTICS

- Fully covered and enclosed design.
- Dust-emission free operation.
- Protection from moisture and environmental influences.
- Drive station equipped with belt scrapers and dust collection hopper and transport system.
- Tail station equipped with screw tensioning device of the belt up to 60 m length, and with additional 750 mm case for belt tensioning for longer lengths.
- Material return by special hopper and dedicated tubular spiral conveyor.
- Belt running on 3-rolls transoms and permanently cleaned by internal and external belt scrapers.
- Watertight external top cover realized by hot dip galvanized steel sheet, suitable for outside installation and fixed by bolts.

Technical data					
Capacity		RBC600E	RBC800E	RBC1000E	RBC1200E
(Bulk density 750 kg/m ³) weight	Weight	400 t/h	600 t/h	800 t/h	1000 t/h
	Volume	533 m ³ /h	800 m ³ /h	1067 m ³ /h	1333 m ³ /h
Belt speed	Nominal	2,5 - 3,5 m/s			
Drive unit		Double right angle gearmotor with backstop in case of inclination			
Sound pressure level		Up to 70 dB(A)			
Operating conditions		-15°C to +40°C ambient			

Materials			
Casing	Standard	Hot-dip galvanized high tensile steel S235 Z450	
	Optional	Hot-dip-galvanised S235 Z900 Stainless steel Painted steel	
Belt	Standard	Oil-resistant acc. DIN22102 Self-extinguishing acc. DIN22103 Antistatic acc. DIN22104 Polyester polyamide fabrics Black color	
	Optional	Food-safe White color PVC material	
Idlers	Conveying	Steel	1250 mm spacing
	Impact	Steel with rubber rings	350 mm spacing
	Return	Steel with rubber rings	2500 mm spacing
Sensors	Standard	Rotation sensor	
	Optional	Misalignment sensor Overflow sensor Bearing temperature sensors Emergency rope	
ATEX	Standard	Zone 21 inside / ATEX free outside	
	Optional	Zone 21 inside / Zone 22 outside	
Optional accessories	Inlet module Outlet module with belt scraper Counterweight tensioning device Top covers and bottom plates for intermediate outlets Supporting legs		

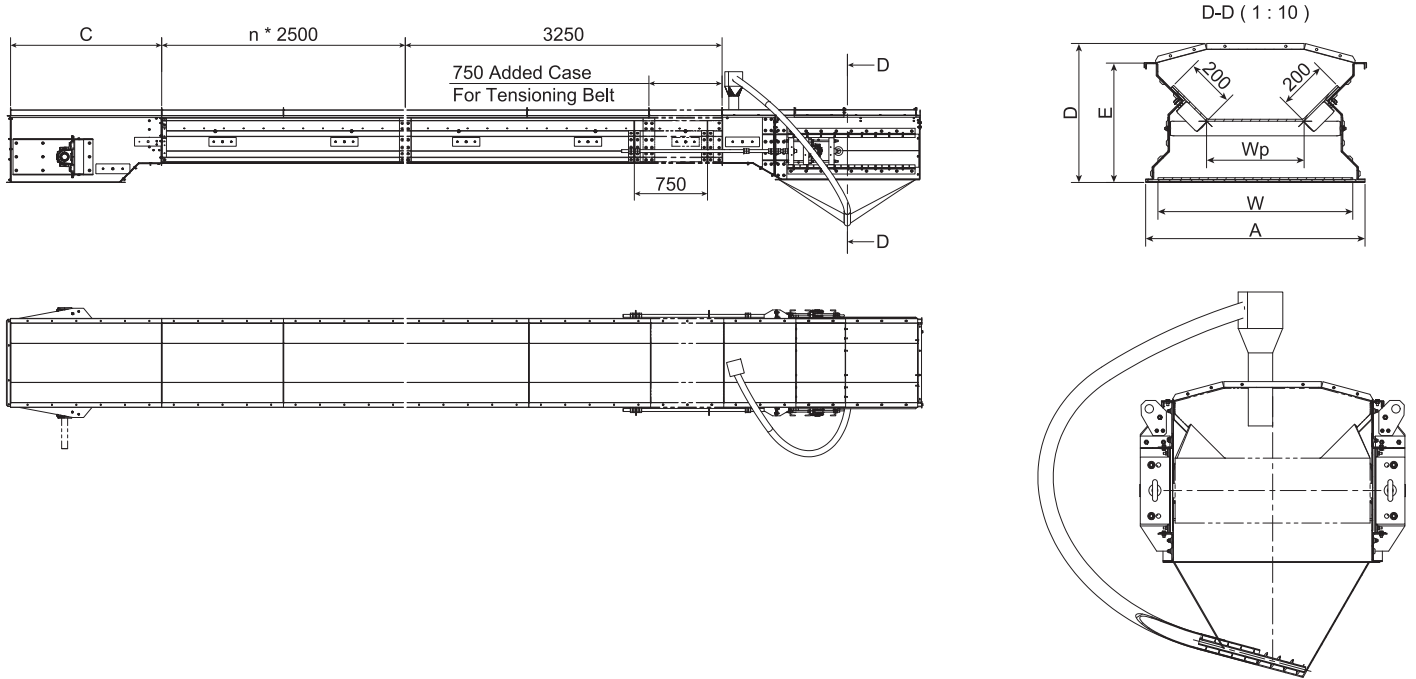

Belt conveyor dimensional drawing.



A manual spindle tensioning system can be combined with a 750 mm supplementary case to accommodate larger belt tensioning needs.



Split pillow block bearings for simplified assembly and maintenance.



All rolls can be easily inspected, maintained, and exchanged from the outside.



Material that falls from the upper conveyor section is transported back to the end of the conveyor by the returning belt. A specially designed hopper collects the material, which is then conveyed back to the upper part of the belt via a dedicated tubular spiral conveyor.

Type	Belt width W mm	A mm	Wp mm	C mm	D mm	E mm
RBC 600E	600	700	200	1450	520	490
RBC 800E	800	900	400	1550	571	490
RBC 1000E	1000	1100	600	2150	693	550
RBC 1200E	1200	1300	800	2550	750	550

The casing can be 500 mm, 1000 mm, 2000 mm or 3000 mm long.