



The CESCO Smooth Square Silo (SSS) is a modular, efficient, and versatile storage system designed for the safe and well-organized storage of grain, seed and compound feed.

CESCO's versatile square silos help address space limitations and seismic challenges in process plants, thereby enhancing safety and cost-efficiency, especially during facility expansions. This type of silo is often preferred when aesthetics and exterior design are more important or when avoiding the presence of ridges and valleys in corrugated silos is a priority.

#### ADVANTAGES

- Compact and modular design utilizing fully bolted technology for simplified erection and transport.
- Up to 38% higher storage capacity compared to round silos.
- The absence of gaps between silos eliminates residual spaces, reducing the risk of mold, fungi, or insect contamination.
- fully bolted design: materials are well packed, reducing shipping volume and costs, while allowing for easy and cost-effective on-site assembly.
- Exceptional corrosion resistance achieved through comprehensive coating of cavities in the double-walled components or stainless steel.
- Homogeneous material storage possible.
- No product adhesion in the silo.

#### DESIGN

- Cell lengths range from 2000 mm to 4000 mm in 250 mm increments.
- Cell heights range from 3 m to 30 m in 620 mm increments.
- Cell wall width available in thicknesses of 100 mm and 150 mm.
- Outer walls of the cells designed for cladding attachment using sheet metal or polyurethane sandwich panels.
- Cell outlet hopper with a central outlet or multi-hopper.
- Includes substructure, frame, ladders, and operating platforms.
- Multiple coating options are available, including paint, galvanization, or stainless steel materials for both internal and external surfaces.

#### Principle of operation



The silo cells in the modular design can be installed as a battery of silos in a row or as a block with different heights and capacities. The silo block can seamlessly integrate into the steel structures of machine houses or mill buildings. Product adhesion is prevented due to the completely smooth double-wall elements and the use of countersunk head screws inside the silo.

Each silo is composed of double-wall elements that are securely screwed together. Each wall element features a lateral structure forming a quarter beam. When four double-wall elements come together, they create a hollow beam, which can be filled with concrete after installation to ensure the silo's high rigidity.

In addition, each silo cell is equipped with a bolted outlet hopper, providing both central round and multi-hopper outlet options.



- 1 Single bin
- 2 Corner column
- 3 Wall column
- 4 Multi-hopper
- 5 Central tronco-conical hopper
- 6 Supporting structure
- 7 Wall cladding
- 8 Roofing
- 9 Machine house

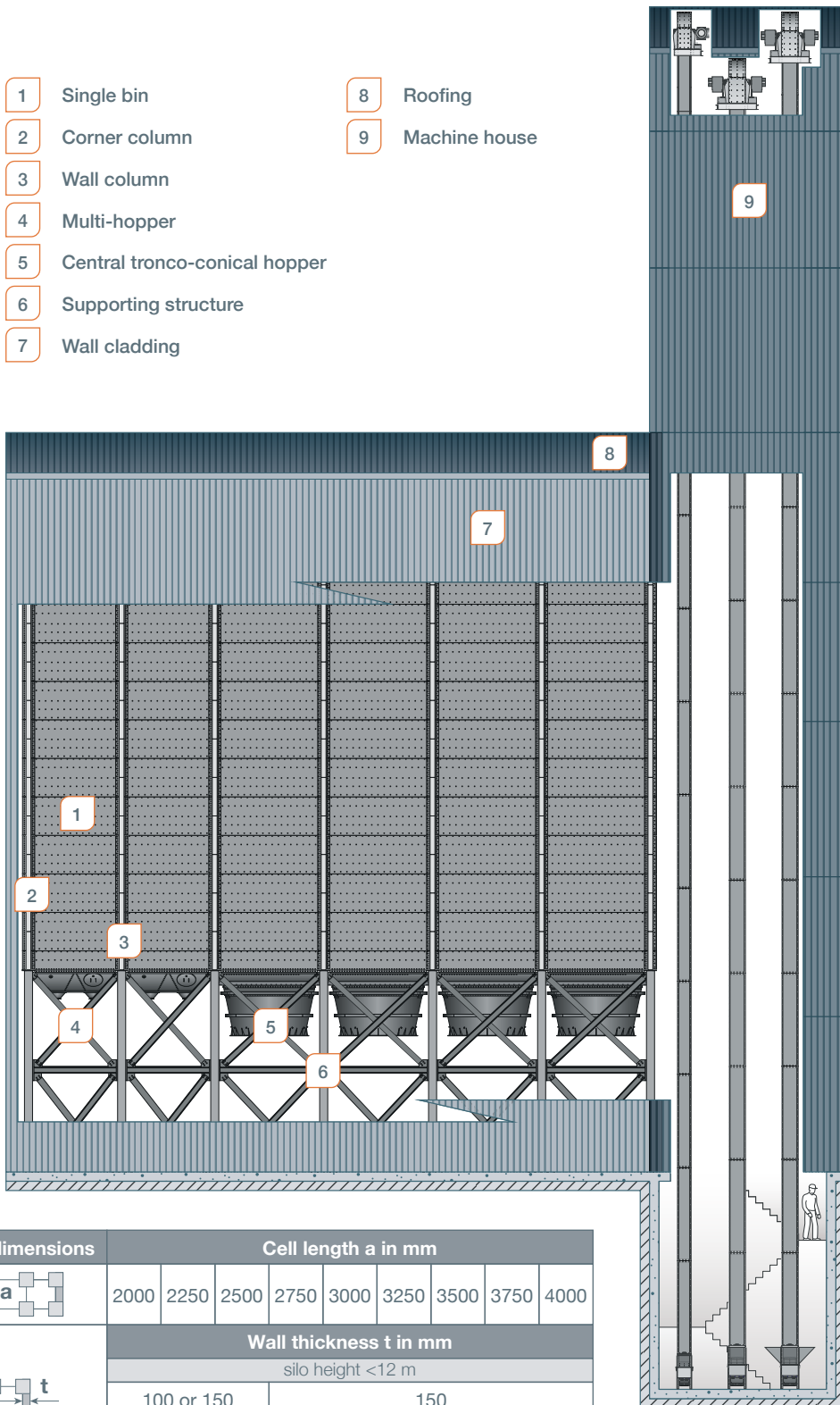

Compact 2x4 plus 2x2 silo battery with supporting structure.



The roof of the cells can be constructed either with a reinforced concrete cover cast on a corrugated galvanized steel sheet bed or using a globular sheet cover and a lightweight beam network.

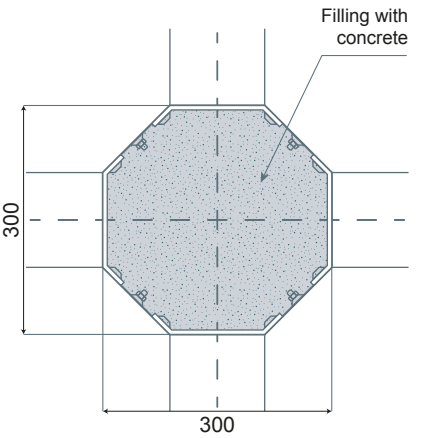

SSS wall elements are available with either a painted or galvanized surface coating, or in stainless steel.



Horizontal cross section of internal column.

Cell dimensions	Cell length a in mm								
	2000	2250	2500	2750	3000	3250	3500	3750	4000
	Wall thickness t in mm								
	silo height < 12 m								
	100 or 150			150					
	silo height > 12 m								
	150								
Various cell configurations and divisions, including options such as half or quarter cells, are available upon request.									